



Elektrotechnische Fabrik
GmbH & Co. KG

Bevertalstr. 20
D-42499 Hückeswagen
Phone: +49 2192 9166 0
Fax: +49 2192 9166 66

Installation Instructions

Cable fuse box HSW 2210

Intended use

The cable fuse box HSW 2210 is intended to be used in suitable lighting poles.

The cable fuse box HSW 2210 is designed for the connection of max. 3 underground cables.

Any other use of this product requires the consultation with the manufacturer.

Safety instructions

When working on electrical systems, the valid regulations such as VDE 0100 must be observed. Installation may only be carried out by qualified personnel or instructed persons in a de-energized state.

Service

In the event of malfunctions or complaints regarding the product, please contact your sales representative or the manufacturer.

Technical data

Nominal voltage / -current	400 V / 16 A
Degree of protection	IP54
Protection class	II
Fuses	2 x D01 (E14) 16 A / 400 V
Measurements (L x W x H)	290 x 84 x 72 mm
Pole internal diameter	from Ø 89 mm
Door size	80 x 300 mm
Entry field for wire connection	up to 110 mm
Input connectors	max. 3 cables 5 x 6 – 5 x 16 mm ²
Output connectors	L max. 2 x 2,5 mm ² N max. 2 x 2,5 mm ² PE max. 3 x 2,5 mm ²

Mounting in lighting poles

- Remove housing cover
- Remove bridge clamp
- Insert the cable fuse box into open lighting pole and fasten it to the mounting rail

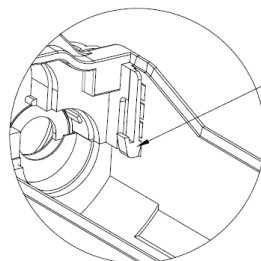

Bridge clamp strain relief can be snapped into the lower part of the housing for easier installation. For disassembly, the side lugs must be operated with a slot screwdriver

Adjust input seal

- Important!** With one input cable, always use the existing opening of the input seal!
- Break out the inlet seal at the engraved points according to the number and diameter of the input cables

Connecting the input cable

- Strip the input cable and remove the filling material
- Insert the input cable so that the outer sheath extends into the connection compartment
- Snap on bridge clamp and screw tight
- Bending, shortening and stripping cable conductors to suit
- Mount or remove the PE/N - N connection, if present, as required*
- Insert the cable cores into the U-profiles according to the terminal assignment and fasten with the self-locking sliding clamps (torque max. 2 Nm)
- Snap the contact hazard protection cover on

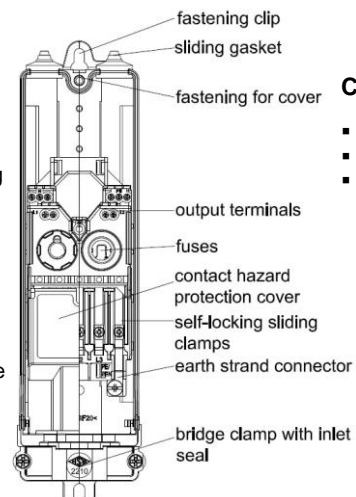

Connecting the output cable

- Cut off the nipple of the outlet seal to be used
- Slide outlet seal over output cable
- Strip output cable
- Insert the outlet seal with output cable into the slot of the cable fuse box
- Pull the output cable back a little so that the outgoing seal is in full contact with the cable
- Shortening and stripping cable conductors to suit
- Connect the cable cores to the output terminals of the insert (torque max. 0.8Nm) or to special components according to the cable assignment

Assembly

- Fit housing cover, snap the housing cover and screw it tight

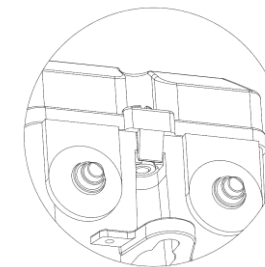

Special components

- When special components are used, the respective regulations of the devices used must be observed

Changing fuse inserts

- Remove housing cover
- Remove screw caps and change fuse insert
- Attention!** Do not remove the contact hazard protection cover! It prevents from the accidental contact with live parts!



Elektrotechnische Fabrik
GmbH & Co. KG

Bevertalstr. 20
D-42499 Hückeswagen
Phone: +49 2192 9166 0
Fax: +49 2192 9166 66

Installation Instructions

Cable fuse box HSW 2210

Intended use

The cable fuse box HSW 2210 is intended to be used in suitable lighting poles.

The cable fuse box HSW 2210 is designed for the connection of max. 3 underground cables.

Any other use of this product requires the consultation with the manufacturer.

Safety instructions

When working on electrical systems, the valid regulations such as VDE 0100 must be observed. Installation may only be carried out by qualified personnel or instructed persons in a de-energized state.

Service

In the event of malfunctions or complaints regarding the product, please contact your sales representative or the manufacturer.

Technical data

Nominal voltage / -current	400 V / 16 A
Degree of protection	IP54
Protection class	II
Fuses	2 x D01 (E14) 16 A / 400 V
Measurements (L x W x H)	290 x 84 x 72 mm
Pole internal diameter	from Ø 89 mm
Door size	80 x 300 mm
Entry field for wire connection	up to 110 mm
Input connectors	max. 3 cables 5 x 6 – 5 x 16 mm ²
Output connectors	L max. 2 x 2,5 mm ² N max. 2 x 2,5 mm ² PE max. 3 x 2,5 mm ²

Mounting in lighting poles

- Remove housing cover
- Remove bridge clamp
- Insert the cable fuse box into open lighting pole and fasten it to the mounting rail

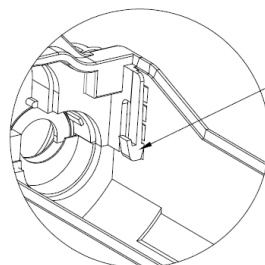

Bridge clamp strain relief can be snapped into the lower part of the housing for easier installation. For disassembly, the side lugs must be operated with a slot screwdriver

Adjust input seal

- Important!** With one input cable, always use the existing opening of the input seal!
- Break out the inlet seal at the engraved points according to the number and diameter of the input cables

Connecting the input cable

- Strip the input cable and remove the filling material
- Insert the input cable so that the outer sheath extends into the connection compartment
- Snap on bridge clamp and screw tight
- Bending, shortening and stripping cable conductors to suit
- Mount or remove the PE/N - N connection, if present, as required*
- Insert the cable cores into the U-profiles according to the terminal assignment and fasten with the self-locking sliding clamps (torque max. 2 Nm)
- Snap the contact hazard protection cover on

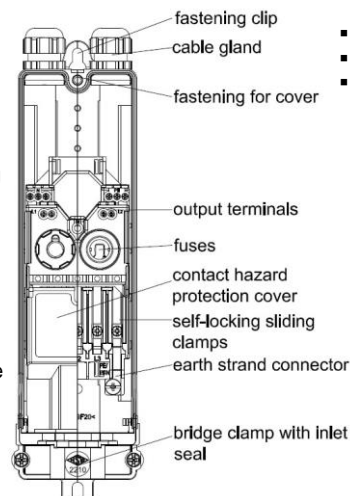

Connecting the output cable

- Strip the output cable, shortening and stripping cores
- Insert the output cable through the cable gland
- Screw the pressure nut together until the seal set between nut and cable forms a small bead
- Connect the cable cores to the output terminals of the insert (torque max. 0.8Nm) or to special components according to the cable assignment

Assembly

- Fit housing cover, snap the housing cover and screw it tight

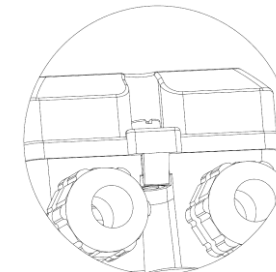

Special components

- When special components are used, the respective regulations of the devices used must be observed

Changing fuse inserts

- Remove housing cover
- Remove screw caps and change fuse insert
- Attention!** Do not remove the contact hazard protection cover! It prevents from the accidental contact with live parts!